

# Experimenter's Corner

By Forrest M. Mims

## THE NEON GLOW LAMP

In this day of solid-state technology, the humble neon glow lamp still has much to offer to the experimenter. Besides its luminescence, the glow bulb displays negative resistance behavior. Because of this, it is often found in voltage regulator and relaxation oscillator circuits. Best of all, glow lamps are inexpensive. You can purchase them from advertisers in the Electronics Marketplace for as little as a nickel each in quantities of several dozen.

Before we look at some interesting glow lamp circuits, let's review some of the basic operating principles of this versatile component. Knowledge of its operating characteristics will enable you to design your own circuits.

An outline view of a typical glow lamp is shown in Fig. 1. Few electronic components are as structurally simple—a glow lamp consists merely of a gas-filled bulb and a pair of electrodes to which wire leads have been attached.

Normally, the resistance of the gas between the two electrodes is so high that the lamp can be considered an open circuit. But when the voltage across the lamp is raised to the critical *initial breakdown voltage*, the gas ionizes and becomes highly conductive. The ionized gas glows with a characteristic color. Neon, the most common filler gas, glows orange. Argon, which is sometimes used, has a blue glow.

Fig. 1. Sketch of neon lamp's construction.

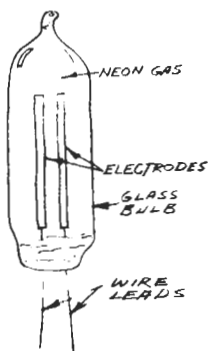
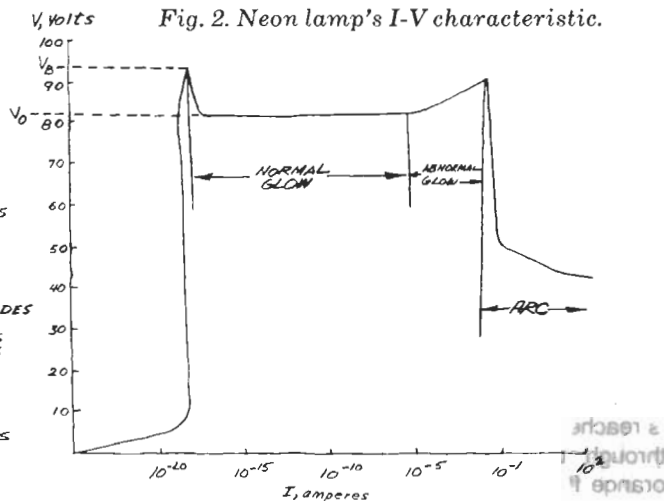

Figure 2 shows the I-V characteristics of a typical neon bulb. Until the breakdown voltage  $V_B$  is reached, current through the lamp is very small. (This voltage will vary between 55 and 150 volts for commercially available bulbs.) When the bulb fires, it enters the *normal glow* region of its I-V curve. In this region, the soft, luminous glow is confined to the negative electrode, and the glow area increases directly with lamp current. The voltage-regulating properties of the neon lamp are self-evident in Fig. 2. A nearly constant voltage drop  $V_0$  exists across the lamp even though the current varies over a wide range.

When current is so high that the entire surface of the electrode is covered by the glow, the voltage across the lamp rises. The neon lamp has then entered the *abnormal glow* region. If lamp current further increases, the lamp is operating in the *arc* region. Here, the voltage across the lamp drops and the orange-colored discharge becomes a bright point of bluish-white light centered on the cathode (negative) electrode. Prolonged operation in the abnormal glow region, and even a brief incursion into the arc region will destroy the lamp.

Although neon lamps operate at fairly high voltages, they consume small amounts of power, and most commercial devices are rated at a continuous current of 0.1 to 10 mA.

Fig. 2. Neon lamp's I-V characteristic.



## Put Professional Knowledge and a COLLEGE DEGREE in your Electronics Career through HOME STUDY



### Earn Your DEGREE

by correspondence, while continuing your present job. No commuting to class. Study at your own pace. Learn from complete and explicit lesson materials, with additional assistance from our home study instructors. Advance as fast as you wish, but take all the time you need to master each topic. Profit from, and enjoy, the advantages of independent study.

The Grantham electronics degree program begins with basics, leads first to the A.S.E.T. degree, and then continues through the B.S.E.E. degree level. Our *free* bulletin gives complete details of the program itself, the degrees awarded, the requirements for each degree, and how to enroll. Write or phone (no collect calls please) and ask for BULLETIN E-77.

**Grantham School of Engineering**  
2000 Stoner Ave., Los Angeles, CA 90025

• Telephone (213) 477-1901 •

Worldwide Career Training thru Home Study

CIRCLE NO. 34 ON FREE INFORMATION CARD

## DIXIE SAVE ON Brand Name Audio Components BY MAIL

### Write Today for Our FREE Audio Catalog

DIXIE is one of the oldest and largest audio component mail order houses in the country. Our prices on brand name components are actually LOWER than "Discounters". See our new catalog or call us for a price quote. Everything shipped factory-sealed with full manufacturer's warranty.

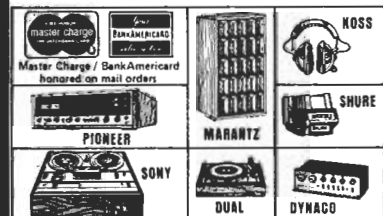

### DIXIE HI-FIDELITY

PE-12

2040 Thalbro Street, Richmond, Va. 23230  
804-257-4241

Please rush me your FREE Audio Catalog and complete information. I understand there is no obligation.

Name \_\_\_\_\_  
Address \_\_\_\_\_  
City \_\_\_\_\_  
State \_\_\_\_\_ Zip \_\_\_\_\_

## Build a Microcomputer System With This \$7.95 Handbook.

At last, a practical, step-by-step approach to building an operational microcomputer for a bargain price. The **Iasis Microcomputer Applications Handbook** will guide you through all phases of actual design of a working 8080 microcomputer system including writing a system monitor program. Both development and OEM systems are covered in detail.



P.S. If the Microcomputer Applications Handbook isn't everything we say it is, return it within 15 days for a full refund.

ORDER BEFORE JAN. 14, 1977 AND WE'LL SHIP YOUR HANDBOOK POST-PAID.

Here's my check or money order for \$7.95. Add \$ .50 for postage and handling if ordered after Jan. 14, 1976. (California residents please add \$3.52 state sales tax.)

Overseas shipments will be made surface unless \$5.00 shipping is added.

Charge to the credit card number below:

BankAmericard No. \_\_\_\_\_

Master Charge No. \_\_\_\_\_

For Master Charge, add 4-digit number from right above name. It is: \_\_\_\_\_

Here's my Signature \_\_\_\_\_

Credit card expiration date \_\_\_\_\_

FIRM \_\_\_\_\_

NAME \_\_\_\_\_

ADDRESS \_\_\_\_\_

CITY \_\_\_\_\_

STATE/ZIP \_\_\_\_\_

MAIL YOUR ORDER TO IASIS, INC.  
815 W. MAUDE AVE., SUITE 13  
SUNNYVALE, CA 94086

**Some Precautions.** Neon glow lamps are simple to use, but you should be aware of a few special restrictions. First, these lamps are subject to what is called the *dark effect*. That is, ionization of the gas is much more easily accomplished in the presence of ambient light. In total darkness, the glow lamp operates erratically, and its breakdown voltage increases significantly. To overcome this problem, many neon lamps contain a minute amount of radioactive gas, which stimulates ionization.

A second operating restriction is the necessity to avoid excessive operating voltages. Too much voltage will cause the lamp to operate in the abnormal glow or arc region. The third consideration is current limiting. It is necessary to place a resistor in series with a continuously operated glow lamp. This *ballast* resistor limits the current through the lamp to a safe value. If we assume that an ionized glow lamp has practically no resistance but a voltage drop of 80 volts, Ohm's and Kirchoff's Laws dictate that a 100,000-ohm ballast resistor will allow a safe 200  $\mu$ A to flow through a glow lamp connected to a 100-volt dc source.

**Glow Lamp Circuits.** Now that we've covered some of the basics of glow lamp operation, let's examine several practical circuits. You can use the miniature dc-dc converter described in last month's column or a pair of 67½-volt batteries connected in series as a power supply.

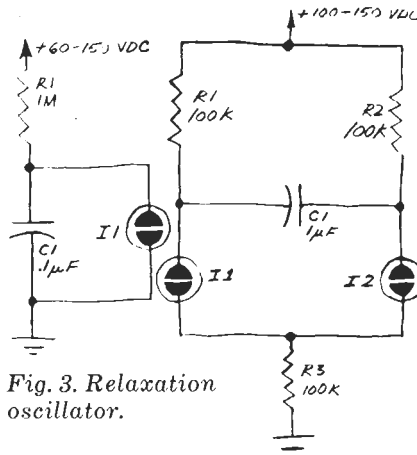

Fig. 3. Relaxation oscillator.

Fig. 4. Astable multivibrator.

The simplest circuit is the glow-lamp relaxation oscillator shown in Fig. 3. In operation,  $C_1$  charges through  $R_1$  until the breakdown voltage of the neon lamp is reached. At that point,  $C_1$  discharges through the lamp and produces an orange flash. When the voltage across

## A Logical Solution to your Digital Logic Problems!



## THE NEW CATCH-A-PULSE® LOGIC PROBE!

- Multi-family
- Open circuit detection
- High input impedance
- Pulse stretching
- 60 Nsec pulse response
- Replaceable tip and cord

Compatible with RTL, DTL, TTL, CMOS, MOS, and Microprocessors using a 3.5 V to 15 V power supply. Thresholds automatically programmed for multi-logic family operation. Automatic resetting memory for single or multi-pulse detection. No adjustment required. Visual indication of logic levels, using LEDs to show high, low, bad level or open circuit logic and pulses. Highly sophisticated, shirt-pocket portable (protective cap over tip and removable coiled cord). Eliminates need for heavy test equipment. A definite plus in time and money for engineer and technician.



Introductory Price  
**\$24.95**  
Plus 1.25 shipping & handling  
Calif. residents add 6% sales tax  
AVR Electronics  
P.O. Box 45167  
San Diego, Ca. 92145  
(714) 566 1570

Dealer inquiries invited

CIRCLE NO. 2 ON FREE INFORMATION CARD

## We have 400,000 reels of great recording tape to unload.

\$30.00 gets you thirty reels (\$225 value); or \$12.50 gets you ten reels (\$80 value). Call for quantity prices. These are government surplus, and fully guaranteed, professional quality mylar tapes on 10½ plastic reels, ¼" wide, 1 MIL with 3600 feet per reel.

Sounds crazy? We can sell brand name tapes at these ridiculous prices because we're the only supplier who bought up 400,000 reels.

Mail your order, name and address, with check or money order (N.Y. residents: add tax) to:

## AMERICAN SURPLUS TRADING

Dept. P

332 Canal Street  
New York, N.Y. 10013  
(212) 966-5650

## SAVE!

MONEY • TIME • FREIGHT

- QUALITY STEREO EQUIPMENT AT LOWEST PRICES.
- YOUR REQUEST FOR QUOTATION RETURNED SAME DAY.
- FACTORY SEALED CARTONS—GUARANTEED AND INSURED.
- SAVE ON NAME BRANDS LIKE:  
A.D.C. KLH  
A.R. SHURE  
DYNACO KOSS  
SONY FISHER

PIONEER  
AND MORE THAN 50 OTHERS  
BUY THE MODERN WAY  
BY MAIL—FROM

# ia illinois audio

Department 217S  
12 East Delaware  
Chicago, Illinois 60611  
312-664-0020

CIRCLE NO. 37 ON FREE INFORMATION CARD  
POPULAR ELECTRONICS

$C1$  drops below the voltage necessary to keep the lamp conducting, the lamp goes dark. Then  $C1$  begins to charge and the cycle repeats.

To see the glow-lamp flash you will have to use at least a 1-megohm resistor. Otherwise the flash rate will be faster than the 18 pulses per second discernible by the human eye and the lamp will appear continuously on. Also, use 200-volt capacitors in this and the following circuits because of the high voltages present.

You can connect an oscilloscope across  $C1$  to verify that the circuit is oscillating if you choose to operate it at audio frequencies. Alternatively, you can connect an 8-ohm speaker between the glow lamp and ground or place the circuit near a radio to actually hear the oscillation frequency or its harmonics.

If you're familiar with neon-lamp relaxation oscillators, you probably know that several circuits like the one shown in Fig. 3 can be cascaded to produce a pseudo-random flashing effect. These circuits are often seen flashing away in electronics labs and are called "do-nothing boxes" or "idiot lights."

An astable multivibrator made from two glow lamps is shown in Fig. 4. If we assume  $I1$  has a lower turn-on voltage than  $I2$ ,  $I1$  will turn on first after power has been applied. This permits  $C1$  to charge through  $R2$  and  $I1$ . When the voltage across  $C1$  exceeds the turn-on voltage of  $I2$ ,  $I2$  turns on and  $I1$  turns off. Now  $C1$  charges through  $R1$  and  $I2$  until its charge fires  $I1$ . Lamp  $I2$  then turns off,  $C1$  begins charging through  $R2$ , and the cycle repeats.

The circuits described here incorporate a relaxation oscillator, and you can easily vary the repetition rates of the oscillators by altering the values for the resistor and capacitor which, together with the lamp, form the oscillator ( $R1$  and  $C1$  in Fig. 3, etc.). Higher values of resistance or capacitance will slow the repetition rate. But try to keep  $R1$  above 100,000 ohms, and  $C1$  below 1  $\mu$ F.

If you do experiment with any of these circuits, be sure to observe standard safety precautions. Even a 67½-volt battery can deliver a sharp shock, and if the shock itself doesn't affect you, the resulting reflex action may dash your wrist or elbow into your work bench or chair.

For best results and optimum safety, stick to batteries or miniature high-voltage power supplies like the one described in last month's column. If you must use line power, never operate a glow-lamp circuit from the ac line without using a 1:1 isolation transformer. ◇

# LEADER 5" QUALITY SCOPES COST LESS THAN EVER!

And They're Complete With Accessories!



**LBO-506A**  
5" Dual Trace/Dual Channel Automatic Triggered Scope  
Highly accurate—sync's to 35MHz. Auto trigger includes TV-V, TV-H, with variable h'z'l sweep and vertical input. Features sep./simul. sw. mode; X5 mag; X-Y display; direct RF input; 10MHz b'width; 10mV-20 Vp-p/cm vert'l sens. in 11 calib. steps. Probes, leads, adapt's incl.  
**A TREND SETTER!**  
\$599.95



**LBO-505**  
5" Trig Dual Trace/Dual Chan. Scope 15MHz Bandwidth  
Outduels them all! With auto & trig sweep; AC or DC c'pl'd per ch; 100 nsec/cm max. speed (X10mag.); sep. or simul. sweep mode display of ch 1 & 2, alter.; chop., algebra added, and vector (x-y); Sweep Range: 1  $\mu$ sec/cm to 0.5sec/cm, 17 steps calib. Probes, leads, adapt's, incl.  
**THE BEST... \$669.95**



**LBO-502**  
5" Triggered Scope w/Graded Scale  
Ideal for most every electronic application; with easy pushbutton operation; 1-2-5 graded scale readings & 15 MHz b'width. Has auto and trig sweep, 17 steps calib.; X5 mag; and 10mV to 20mVp-p/cm vert. sensitivity. Complete with probe, leads and adapter.  
**SAVE \$80.00 NOW \$449.95**



**LBO-511**  
5" Solid State General Service Scope  
Features recurrent sweep w/automatic sync and calib vert'l input — has 140° phase control; and TV-V & TV-H w/4 sweep ranges to 100KHz. DC coupling and push-pull amps provide distortion-free stability across the 10MHz b'width. Complete with probe, leads and adapter.  
**SAVE \$50.00 NOW \$299.95**

**LEADER**  
Instruments Corp.

Tests More... Tests Better... for Less.

151 Dupont Street, Plainview, N.Y. 11803 516-822-9300

CIRCLE NO. 42 ON FREE INFORMATION CARD

## The quick charge iron with 16 different quick change tips.



**ISO-TIP®**  
QUICK CHARGE  
Cordless Soldering Iron completely recharges in 3½-4 hours. Low voltage, battery powered, ground free isolated tip design.

16 snap-in tips to fit any job plus a PC Drill.

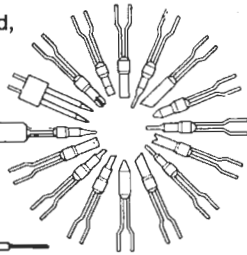

**WAHL CLIPPER CORPORATION**  
ORIGINATORS OF PRACTICAL CORDLESS SOLDERING  
• Sterling, Illinois 61081 • (815) 625-6525  
"Manufacturing Excellence Since 1919"

CIRCLE NO. 69 ON FREE INFORMATION CARD



## A Completely Portable, Polytonic Synthesizer System For Under \$140.00

CONJURE IT UP FROM:

THE GNOME MICRO-SYNTHESIZER kit no. 3740 \$48.95 + 4 lbs. shipping

— AND —

OZ-MINI-ORGAN & POLYTONIC PITCH SOURCE kit no. 3760 \$84.95 + 12 lbs. shipping

Hear them on our 24 hr. Demo-Line (405) 843-7396 and get our FREE CATALOG with more

## Magical Musical Kits

FROM:

**PAIA**

ELECTRONICS DEPT. 12-P  
1020 WEST WILSHIRE BLVD.  
OKLAHOMA CITY, OK 73116

CIRCLE NO. 75 ON FREE INFORMATION CARD

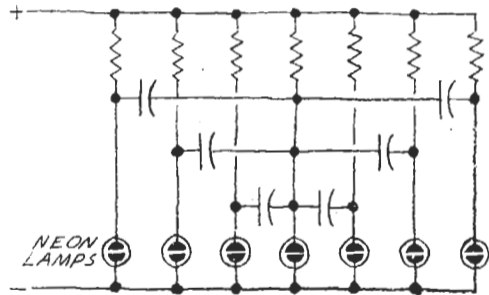

### A Do-Nothing Box

**Q.** *I want to duplicate a Do-Nothing box that a friend of mine has, but it is potted in plastic so I can't see the circuit. The seven neon lamps just blink in a random fashion. How is this done?*

**A.** Use the circuit at the left. Capacitors should be between 0.1 and 1  $\mu\text{F}$  (low leakage); resistors between 220 k and 2.2 megohms. Use a pair of series-connected 67½- or 90-volt dry batteries.

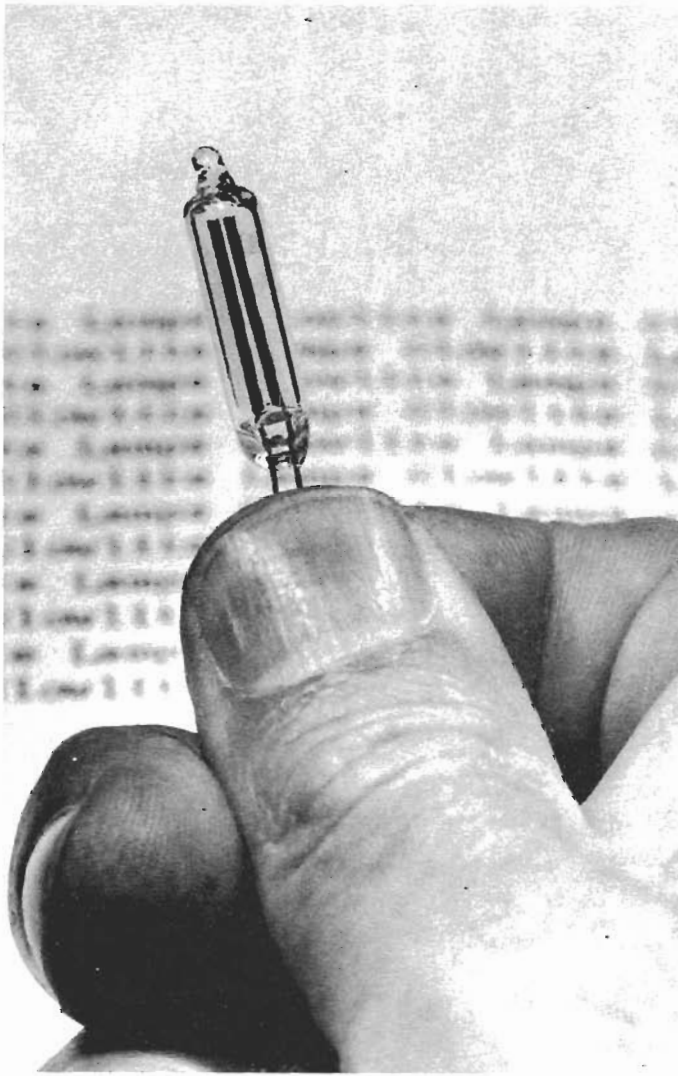

## A Word About GLOW-Lite DIVISION

Glow-Lite is a producer of neon indicator and circuit component lamps, used primarily in appliances and electronic equipment.

In addition to the manufacture of neon lamps, Glow-Lite does a broad range of custom lamp assemblies which include a variety of wire attachments and terminations. Our capabilities in lamp design and production enable us to provide products tailored to fit individual customer's applications.

Glow-Lite's dedication to quality and customer service has made it the leader in the neon lamp industry. This adherence to strict quality and service criteria assures uninterrupted performance for continued customer satisfaction.

**For additional information contact:**  
Glow-Lite Division  
P.O. Box 698  
Hwy. 77 South  
Pauls Valley, Oklahoma 73075  
405-238-5541 • TWX 910-830-6590

CIRCUIT FOR MEASUREMENT OF BREAKDOWN, MAINTAINING, EXTINGUISHING VOLTAGE AND LAMP CURRENT:

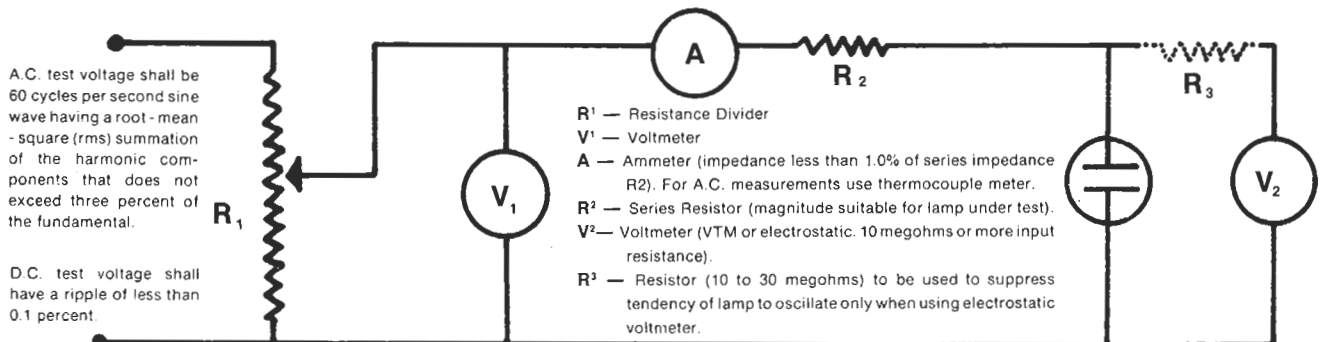

Figure 1

# APPLICATION AND EVALUATION OF GLOW LAMPS

## DEFINITION OF TERMS

**ABNORMAL GLOW** — the area of operation where the change in current causes a greater change in voltage.

**AGING** — the process in which a lamp is subjected to higher than design current for periods greater than 48 hours to stabilize its electrical characteristics.

**BREAKDOWN VOLTAGE** — the voltage required to make the lamp glow (Measured at V 2, Figure 1).

**CORONA** — the visible glow of ionized gas surrounding the cathode.

**DARK EFFECT** — the breakdown voltage can be greatly increased when a lamp is in a darkened environment. By introducing a mild radio-active additive this effect can be reduced.

**DEIONIZATION TIME** — the elapsed time required for a lamp to return to its static breakdown voltage after current ceases to flow.

**DESIGN CURRENT** — the current at which rated life values are based.

**DIFFERENTIAL VOLTAGE** — the difference between the breakdown and maintaining voltage.

**END OF LIFE** — indicator applications define end of life when the light output reaches 50% of its original value. Circuit component applications define end of life when the electrical characteristics are out of specifications.

**EXTINGUISHING VOLTAGE** — the voltage across the lamp when the lamp ceases to glow.

**ION** — the atom which has a deficiency or excess of electrons.

**IONIZATION** — the method of segregating an electron from an atom creating a positive charge and a free electron.

**IONIZATION TIME** — the elapsed time to achieve normal glow after a voltage greater than the breakdown voltage is applied to a lamp.

**MAINTAINING VOLTAGE** — the voltage across the lamp after breakdown occurs.

**NEGATIVE RESISTANCE** — the area of operation where there is an increase in current while the voltage decreases.

**NORMAL GLOW** — the area of operation where the greatest change in current occurs with a minimum change in voltage.

**POLARIZATION** — the change in the electrical characteristics of the electrodes after a lamp is subjected to continued operation at one polarity.

**SPUTTERING** — the depositing of the metal cathode material on the inside walls of the glass container. This occurs when the lamps are operated at high currents.

**STANDING RISE** — the increase in breakdown voltage that occurs when lamps are stored for extended periods of time.

**STATIC BREAKDOWN VOLTAGE** — the voltage required to make the lamp glow when the following conditions exist: 5-50 fc of light, a minimum of 24 hours of nonconducance, and freedom from electrostatic fields.

## PHYSICAL CHARACTERISTICS

**GLASS** — the containing envelope is manufactured from lead glass which is annealed during the manufacturing cycle. This glass is extremely durable and has a high impact strength. If the glass is subjected to gamma radiation it will darken and become brittle.

**GASES** — the ionizable gases used in the manufacture of glow lamps are the "rare" or inert gases. Although neon is the basic gas, the following gases may be used in various proportions to achieve particular characteristics: helium, argon, krypton, and krypton 85.

**ELECTRODES** — the basic metal for all glow lamp electrodes is nickel. Breakdown voltage can be increased by increasing the spacing between the electrodes. All electrodes are coated with emissive materials which enables the lamp to have a lower breakdown voltage and a greater uniformity of photometric characteristics. The length and diameter of the electrode determines the length of glow and current carrying ability respectively.

**RESISTANCE** — all glow lamps require a series resistance to prevent the lamp from burning out. The resistance value

depends on the supply voltage, current, and the desired lamp characteristics. Resistor-attached indicator lamps are not recommended for use in temperatures exceeding 200° F because of the possibility of resistor deterioration.









**PRESSURE** — the increase of the internal gas pressure will result in a higher breakdown voltage, longer life, and reduced light output. If the gas pressure is increased too much the corona will become extremely instable.

**ELECTROSTATIC AND RF EFFECTS** — the existence of an electrostatic field in the proximity of a glow lamp may cause the lamp to ignite at lower voltage levels. The presence of high intensity radio frequency may cause the lamp to ignite without any applied voltage.





**TEMPERATURE** — the operation of indicator lamps in ambients above 300° F is not recommended. The recommended temperature range for circuit component lamps is -60° F to +165° F. Glow lamps have a negative temperature coefficient. The maintaining voltage will decrease with an increase in temperature.

# INDICATOR LAMPS

## HIGH BRIGHTNESS

CATALOG NUMBER	ASA #	MAX. LAMP LENGTH INCHES (MM)	WIRE LENGTH INCHES (MM)	WATTS NOM.	MAX. BREAKDOWN VOLTAGE		CIRCUIT VOLTS	LIFE (HOURS) (AVG.)	RESISTOR
					AC	DC			
 A1C-1	A1C	.500 (12.7)	1 (25.4)	1/7	95	135	120	25,000	47K
 A1C-2	A1C	.500 (12.7)	2 (50.8)	1/7	95	135	120	25,000	47K
 C2A-1	C3A	.750 (19.1)	1 (25.4)	1/4	95	135	120	25,000	30K
 C2A-2	C2A	.750 (19.1)	2 (50.8)	1/4	95	135	120	25,000	30K
 C2A-5	---	.625 (15.9)	1 (25.4)	1/4	95	135	120	25,000	30K
 C2A-6	---	.625 (15.9)	2 (50.8)	1/4	95	135	120	25,000	30K
 D2A-1	D2A	.940 (23.9)	1 (25.4)	1/3	95	135	120	25,000	22K
 D2A-2	D2A	.940 (23.9)	2 (50.8)	1/3	95	135	120	25,000	22K

## STANDARD BRIGHTNESS

CATALOG NUMBER	ASA #	MAX. LAMP LENGTH INCHES (MM)	WIRE LENGTH INCHES (MM)	WATTS NOM.	MAX. BREAKDOWN VOLTAGE		CIRCUIT VOLTS	LIFE (HOURS) (AVG.)	RESISTOR
					AC	DC			
 A1B-1	A1B	.500 (12.7)	1 (25.4)	1/25	65	90	120	25,000	220K
 A9A-1	A7A	.750 (19.1)	1 (25.4)	1/15	65	90	120	25,000	100K
 A9A-2	A9A	.750 (19.1)	2 (50.8)	1/15	65	90	120	25,000	100K
 A1A-4	---	1.060 (26.9)	1 (25.4)	1/15	65	90	120	25,000	100K

## GREEN NEON

CATALOG NUMBER	ASA #	MAX. LAMP LENGTH INCHES (MM)	WIRE LENGTH INCHES (MM)	WATTS NOM.	MAX. BREAKDOWN VOLTAGE		CIRCUIT VOLTS	LIFE (HOURS) (AVG.)	RESISTOR
					AC	DC			
 G2B	---	.750 (19.1)	1.250 (31.8)	1/4	65	90	120	20,000	30K

All lamps are available with radioactive additive to reduce "dark effect".

Wire leads are cut to length per customer specifications.

Leads supplied with cleaned copper finish.









Tinned leads are available.

D.C. life is 60% of A.C. values.

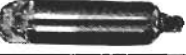
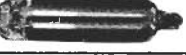
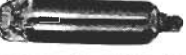
Lamp length can be varied within cataloged range.

Series resistance can be varied to achieve desired light or life characteristics.

# CIRCUIT COMPONENTS

CATALOG NUMBER	D C BREAKDOWN VOLTAGE	D C MAINTAINING VOLTAGE	DESIGN CURRENT (MA)	MAX. LAMP LENGTH INCHES (MM)	LIFE (HOURS) (AVG.)
 NE23	60-90	50 avg.	0.3	.750 (19.1)	6,000
 NE68	60-90	52-65	0.3	.940 (23.9)	6,000
 NE75	60-90	55	0.4	.750 (19.1)	10,000
 NE76	68-76	50-60	0.4	.940 (23.9)	2,000
 NE80	60-80	50-58	0.3	.940 (23.9)	6,000
 NE81	64-80	50-60	0.3	.940 (23.9)	6,000
 NE82	63-76	50-60	1.5	.940 (23.9)	2,000
 NE83	60-100	60 avg.	5.0	.940 (23.9)	5,000
 NE86	55-90	55 avg.	1.5	.940 (23.9)	2,000
 NE98	65-80	50	0.3	.750 (19.1)	6,000
 CC-2	180-250	100 max.	----	.750 (19.1)	----

All lamps are available with radioactive additive to reduce "dark effect".  
 Wire leads are cut to length per customer specifications.  
 Leads supplied with cleaned copper finish.  
 Tinned leads are available.  
 D.C. life is 60% of A.C. values.  
 Lamp length can be varied within cataloged range.  
 Series resistance can be varied to achieve desired light or life characteristics.

## NEON FLASHER LAMP

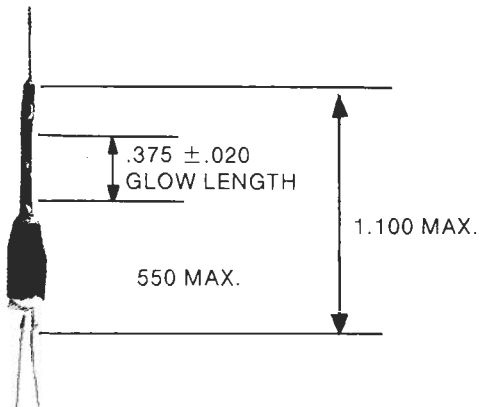

Glow-Lite Division's new Neon Flasher Lamp provides 20 times more brightness than any conventional neon lamp. Designed specifically to provide flashing visual indication in sonar devices, the Neon Flasher operates at 1200 VDC and provides 5,000 average life hours at 5 ma with a 20 percent duty cycle. However, it can easily be used in any electronic equipment requiring ultrabrightness, long life and reliability.



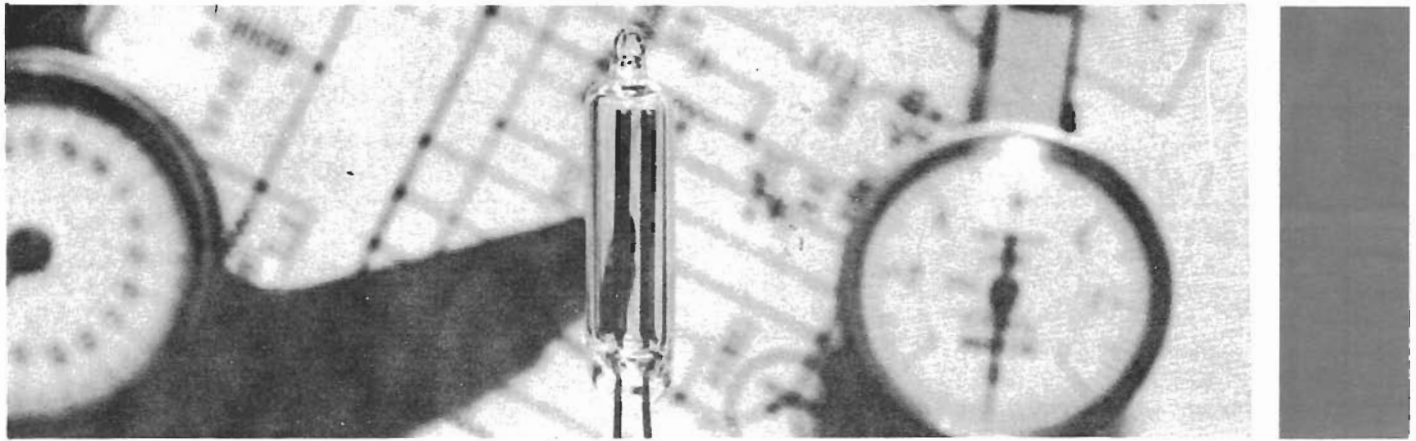

### SPECIFICATIONS

Maximum Starting Voltage .....	1000 VDC
Maximum Maintaining Voltage .....	300 VDC
Life .....	5,000 hours
Design Current .....	5 ma









## BASED GLOW LAMPS

CATALOG NUMBER	ASA #	MAX. OVERALL LENGTH INCHES (MM)	WATTS NOM.	MAX. BREAKDOWN VOLTAGE		LIFE (HOURS) (AVG.)	RESISTOR	BASE
				AC	DC			
 NE-2J	C9A	.940 (23.9)	1/4	95	135	25,000	30K	S.C. MIDGET FLANGE
 NE-2D	C7A	.940 (23.9)	1/15	65	90	25,000	100K	S.C. MIDGET FLANGE
 NE-4	---	1.750 (44.5)	1/15	65	90	25,000	100K	TELEPHONE SLIDE
 NE-84	K1A	1.031 (26.2)	1/4	95	135	25,000	30K	MIN. TELEPHONE SLIDE

## T-3 1/4" MINIATURE BAYONET BASE NEON LAMP

CATALOG NUMBER	ASA #	MAX. OVERALL LENGTH INCHES (MM)	BASE	WATTS NOM.	MAX. BREAKDOWN VOLTAGE		CIRCUIT VOLTAGE	LIFE (HOURS) (AVG.)	RESISTOR
					AC	DC			
 NE51	B1A	1.186 (30.1)	MIN. BAYONET	1/15	65	90	120	25,000	100K*
 NE51-R	---	1.186 (30.1)	MIN. BAYONET	1/15	65	90	120	25,000	100K**
 NE51H	B2A	1.186 (30.1)	MIN. BAYONET	1/4	95	135	120	25,000	30K*
 NE51H-R	---	1.186 (30.1)	MIN. BAYONET	1/4	95	135	120	25,000	30K**

\*EXTERNAL RESISTOR NOT INCLUDED  
 \*\*RESISTOR INCLUDED IN BASE

All lamps are available with radioactive additive to reduce "dark effect".  
 Series resistance can be varied to achieve desired light or life characteristics.  
 D.C. life is 60% of A.C. values.  
 Lamp length can be varied with cataloged range.

## RESISTOR ATTACHED GLOW LAMP

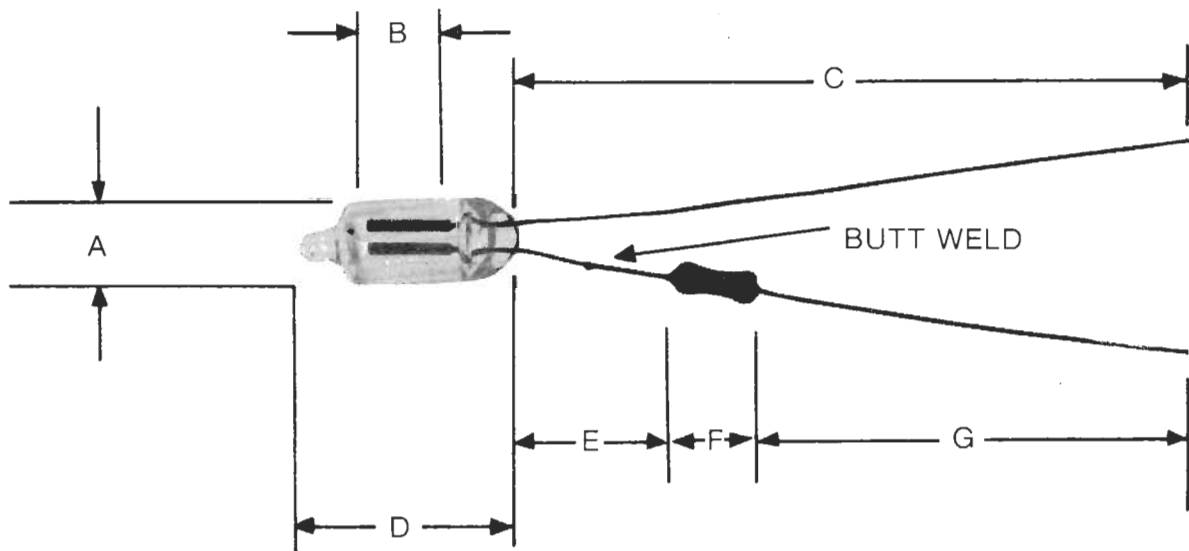

- (A) .235" (6 MM) MAX. OR .244" (6.2 MM) MAX.  
 (B) 3.5 MM, 6 MM, 7 MM, 12 MM, OR 15 MM  
 (C) 1" (25.4 MM)  $\pm$  .062" (1.6 MM) OR 2" (50.8 MM)  $\pm$  .062" (1.2 MM)  
 (D) .480" (12.2 MM) MAX., .500" (12.7 MM) MAX., .625" (15.9 MM) MAX.  
 .750" (19.1 MM) MAX. OR 1.060" (26.9 MM) MAX.  
 (E) .187" (4.8 MM) MIN.  
 (F) 1/4 WATT = .250" (6.4 MM) MAX. OR 1/3 WATT = .375" MAX. (9.6 MM)  
 (G) .125" (3.2 MM) MIN. - 1.5" (38.1 MM) MAX. (WITHOUT WELDING ADDITIONAL WIRE)

All lamps are available with radioactive additive to reduce "dark effect".  
 Wire leads are cut to length per customer specifications.  
 Leads supplied with cleaned copper finish.  
 Tinned leads are available.  
 D.C. life is 60% of A.C. values.  
 Lamp length can be varied within cataloged range.  
 Series resistance can be varied to achieve desired light or life characteristics.

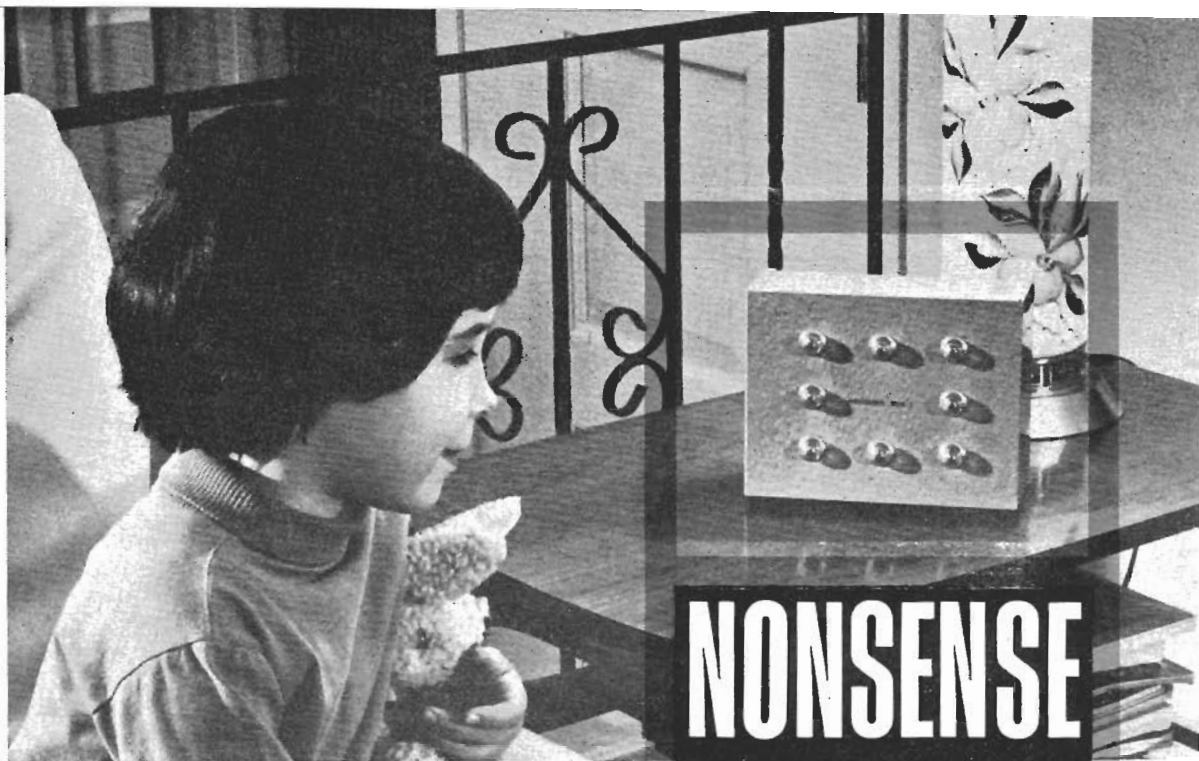

***The most useless thing ever published,  
but your children will think it's great***

# NONSENSE BOX

By ALAN L. DANZIS

**Y**OU MIGHT tell your kids it's a scintillation counter detecting cosmic messages from outer space. Or, you casually can mention to friends the fact that it's a miniaturized digital computer reading out answers in binary computations. Chances are they'll believe every word you say; only you will know that this box is actually "nonsense."

The "Nonsense Box" consists of eight neon lamp flashing circuits flashing at various independent time rates, and all powered by a single 90-volt battery. The current drain imposed by this circuit is around 65 microamperes and the battery should last well over a year. Of course, this is one of the *advantages* (?) of the Nonsense Box—there is no switch to turn it off.

**How It Works.** Each flashing circuit consists of a neon glow lamp, a 0.5  $\mu$ f. 200-volt capacitor and a resistor of one of four specified values from 4.7 to 8.2 megohms. Take a look at the first flashing circuit (*NE1*, *C1*, and *R1*). Since

there is no current flowing in the circuit, there is no voltage drop across *R1*, or the resistor *R9* in series with the battery. This permits *NE1* to fire (conduct) setting up a voltage drop across *R1* and charging *C1*. As the charge across *C1* rises, the voltage across the neon bulb drops, and *NE1* is extinguished. Now *C1* slowly discharges through *R1* (the old *R/C* time constant effect) until sufficient voltage builds up across the neon bulb to fire it and cause the whole process to repeat itself.

Even though the flashing circuits are doubled up (*C1/R1* and *C5/R5* have the same values), small capacitor and resistor mismatches insure that no two flashing circuits have the same time constant. Resistor *R9* helps insure the random nature of the firing pattern.

**Construction.** The Nonsense Box can

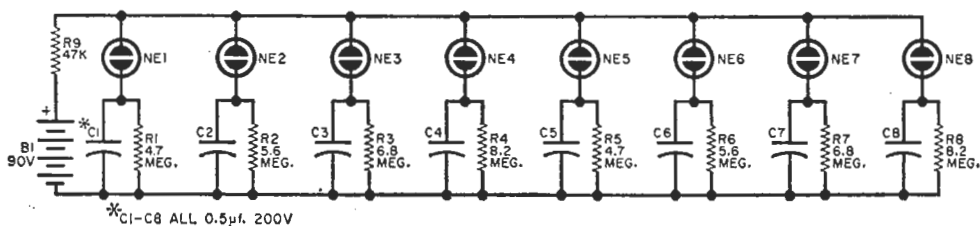

The neon lamps can be arranged in any pattern desired—circle, square, etc.

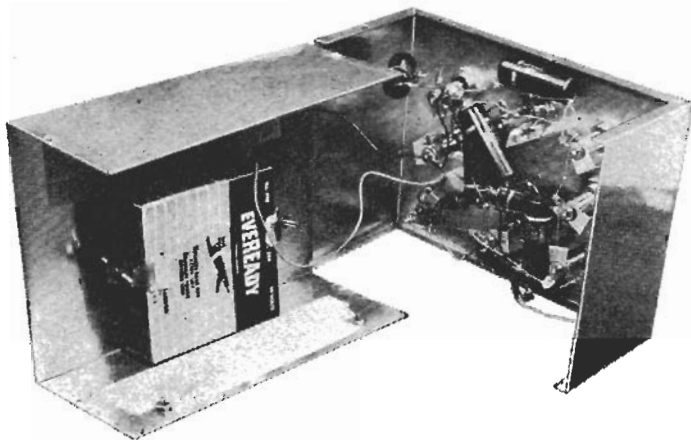

#### PARTS LIST

- B1—90-volt "B" battery (Burgess type V60 or Eveready type 479)
  - C1-C8—0.5  $\mu$ f., 200-volt paper capacitors (eight required)
  - NE1-NE8—NE-51 type neon bulb (eight required)
  - R1, R5—4.7 megohms
  - R2, R6—5.6 megohms
  - R3, R7—6.8 megohms
  - R4, R8—8.2 megohms
  - R9—47,000 ohms
  - S—Neon lamp socket (Dialco type 810-B with clear plastic lens)
  - Misc.—Mounting box, battery retaining clamp, wire, solder, etc.
- All resistors  
1/2-watt

The interior wiring of the Nonsense Box can be as haphazard as you want. Be sure to clamp the battery in place to prevent it being shaken loose.

in the square fashion shown in the photos.

Wiring is noncritical—even the battery polarity may be reversed. It is suggested that one terminal of each of the eight lamp sockets be wired together. Solder one end of R9 to this common connection and leave the other end temporarily free. Now solder one end of resistors R1-R8 and capacitors C1-C8 to each of the unused lamp socket terminals according to the wiring schematic. Bring all 16 free leads from these capacitors and resistors to a common bus bar and solder. The two leads from the battery connect to the free end of R9 and the common bus bar.

The Nonsense Box should start flashing immediately—and only you will know that it's all "nonsense."

-30-

be made of either metal or wood. It should have sufficient space inside to comfortably hold the neon bulb sockets and permit the battery to be mounted rigidly in place. The latter measure is especially necessary since many people will try to shake the Nonsense Box to make it turn off.

Care should be exercised in laying out the holes for mounting the neon lamps. The spacing is not critical, but uniformity is desirable. The lamps could be arranged to make a person's initial, or

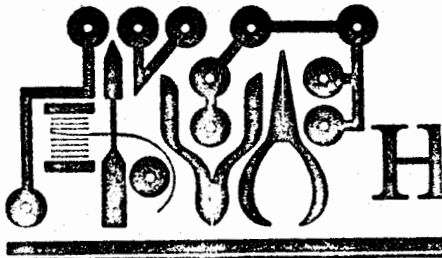

### Neon Lamp on a Transistor Switch

**Q.** I would like to operate a neon lamp from a transistor switch. I have heard that there is a way to do this using low-voltage (therefore low-cost) silicon switching transistors. Do you know of such a circuit?

**A.** You can't just stick a neon lamp in series with a conventional transistor since the high voltage required for the neon would "pop" the transistor. However, you can use the circuit

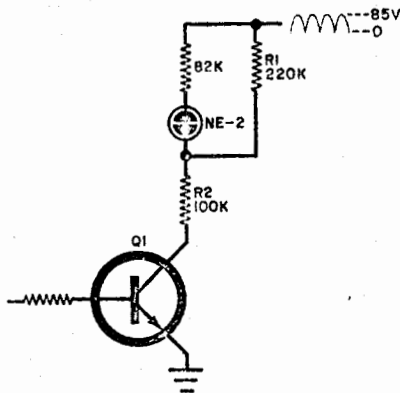

shown here. Resistors  $R1$  and  $R2$  are selected so that the drop across  $R2$  is safe for the transistor and the drop across  $R1$  is less than the striking voltage of the neon lamp. When the base of  $Q1$  is grounded, the lamp is off. A positive base signal turns on  $Q1$  and the lamp. A 25-volt transistor and an 85-volt half-wave supply are needed.

### NEON BLINKER

The circuit shown here is an astable multivibrator employing two neon bulbs that alternately blink on and off. It will delight children when used as the blinking eyes of a Santa Claus, jack-o-lantern or similar toy and can be used to create eye-catching window displays. Type NE-2 or NE-51 neon bulbs can be employed, and the operating voltage (190 to 1150 volts) can be derived from a high voltage photographic battery, a line powered

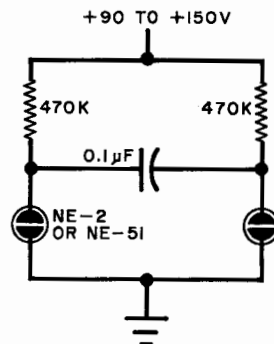

supply, or a small dc-to-dc converter and a low-voltage battery. Current drain is very low, so long battery life can be expected. The flash rate can be changed by varying the values of resistance (don't reduce below 100,000 ohms) and or capacitance. Use a non-polarized capacitor with an adequate voltage rating. —H. Muller, Danboro, PA.